

- For continuous level measurement of liquids (even if polluted), mash and paste materials in open or closed vessels, sumps, open channels, etc.
- Customer choice of the maximum measurement range (by type)
- Current (4 ... 20 mA) or voltage (0 ... 10 V) output, RS-485 Modbus RTU
- Simple installation without setting buttons
- Direct connection into binary input of control system (RS-485).
- Protection class IP68

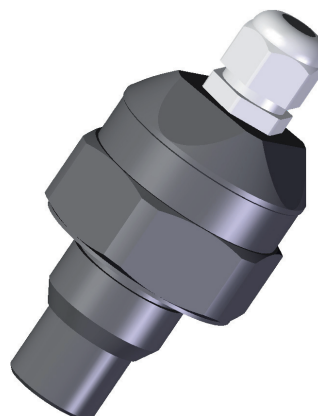

Ultrasonic level meters ULM[®] is self contained device that includes electroacoustics transducer and electronic module. The level meter ULM transmits series of ultrasonic pulses which propagates towards the liquid surface. Reflected acoustic wave is received back in the ULM transducer and processed in electronic module. The distance calculations are based on time of flight of the acoustic wave to the level and back.

The level meters are suited to continuous non-contact level measurement of liquids (water solutions, sewerage water, etc.), mash and paste materials (sediments, sticks, resins etc.) in closed or open vessels, sumps, reservoirs and open channels.

ULM-53L-__-I and ULM-53L-__-U level meters has no customer accessible adjusting elements. Customer choice of the maximum measurement range (factory settings), The outputs can be current (4 ... 20 mA) or voltage (0 ... 10 V).

ULM-53L-__-M level meters has no customer accessible adjusting elements. Two-way communication (parameterization) by RS-485 Modbus RTU protocol.

FEATURES OF VARIANTS

| | |
|----------------------|--|
| ULM-53L-02-__ | Measuring range from 0.25 m to 2 m (customer configurable), plastic PVDF (Polyvinylidene Fluoride) transmitter and plastic body, process connection with thread G 1". |
| ULM-53L-06-__ | Measuring range from 0.25 m to 6 m (customer configurable), plastic PVDF transmitter and plastic body, process connection with thread G 1 1/2". |
| ULM-53L-10 | Measuring range from 0.5 m to 10 m (customer configurable), plastic PVDF transmitter and plastic body, process connection with PP (Polypropylene) flange. |
| ULM-53L-20 | Measuring range from 0.5 m to 20 m (customer configurable), plastic PVDF transmitter and plastic body, process connection with aluminium flange. |

DIMENSIONAL DRAWINGS

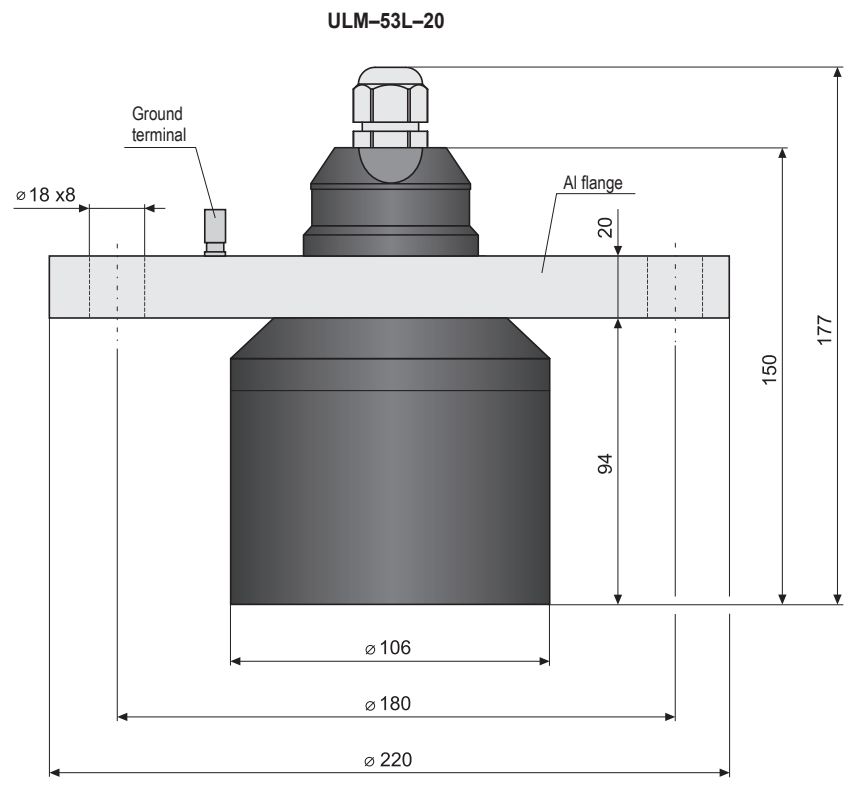
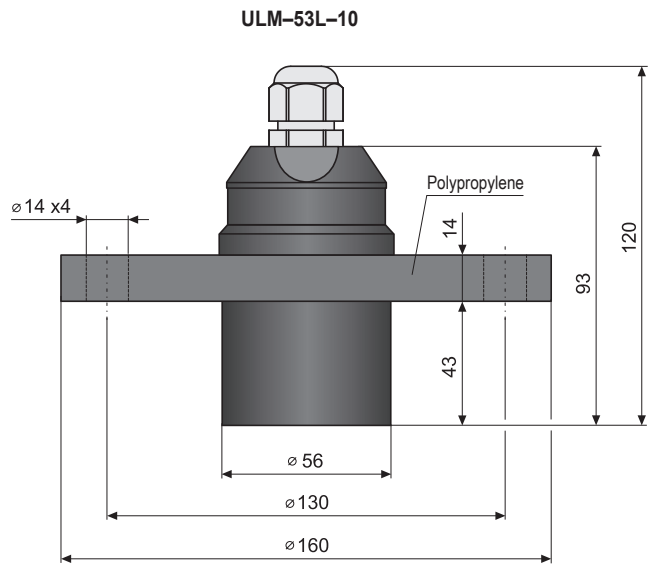
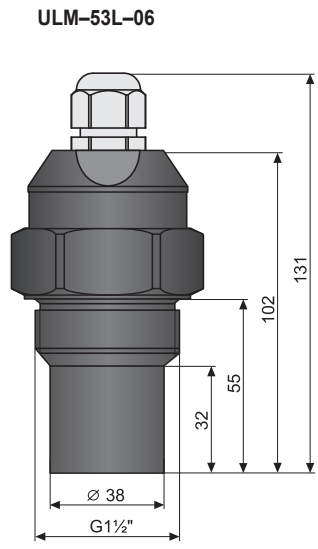
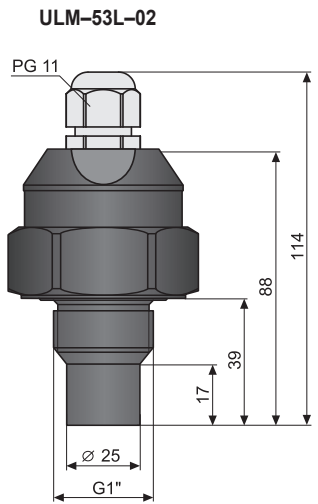

INSTALLATION

Level meter is installed into the upper lid of the tank (vessel), using a fixing nut or a flange.

If installed in an open channel (sumps, reservoirs, etc.), install the level meter as closest as you can to the maximum level expected.

The front of the level meter must run in parallel to the measured level.

Emitted acoustic signal must not be affected by near objects (stiffeners, ladders, mixers, unevenness, etc.), stream of filling, air flow, etc.

In case the level of bulk-solid materials is measured, the measurement range is reduced. We recommend to consult the use with the manufacturer.

Foam on the level absorbs the acoustic wave reflection which might cause malfunction of the level meter. If possible select the location where the foaming is as low as possible.

Protect the level meter against direct sunlight.

In the case of uncertainty we recommend to consult the application with the producer.

| TECHNICAL DATA | | |
|---|----------------------|---|
| Measuring range | ULM-53L-02 | 0.25 ... 2 m |
| | ULM-53L-06 | 0.25 ... 6 m |
| | ULM-53L-10 | 0.5 ... 10 m |
| | ULM-53L-20 | 0.5 ... 20 m |
| Supply voltage | | 18 ... 36 V DC |
| Current supply | ULM-53L-__-U | 12 mA |
| | ULM-53L-__-M | 25 mA |
| Current output (-I) | | 4 ... 20 mA (limit values 3.9 ... 20.5 mA) |
| Voltage output (-U) | | 0 ... 10 V (limit values 0 ... 10.2 V) |
| RS-485 output (-M) | | Modbus RTU protocol |
| Resolution | | < 1 mm |
| Accuracy (within the total range) | ULM-53L-06; -10; -20 | 0.2 % |
| | ULM-53L-02 | 0.3 % |
| Temperature error | | Max. 0.04% / K |
| Beamwidth (-3 dB) | ULM-53L-02, -10 | 10° |
| | ULM-53L-06 | 14° |
| | ULM-53L-20 | 12° |
| Ambient temperature range | ULM-53L-02; -06 | -30 ... +70°C |
| | ULM-53L-10; -20 | -30 ... +60°C |
| Measuring period | ULM-53L-02 | 0.6 s |
| | ULM-53L-06 | 1.0 s |
| | ULM-53L-10 | 1.8 s |
| | ULM-53L-20 | 5.0 s |
| | ULM-53L-__-M | setting by Modbus RTU |
| Averaging | ULM-53L-__-I; -U | 4 measuring |
| | ULM-53L-__-M | setting by Modbus RTU |
| Short time temperature stress resistance | | +90°C / 1 hour |
| Max. operation overpressure (on transmission surface) | | 0.1 MPa |
| Failure indication (by type) | echo failure | 3.75 mA / 0 V / Modbus RTU |
| | level in dead zone | 22 mA / 10.5 V / Modbus RTU |
| Protection class | | IP68 |
| Cable | ULM-53L-__-I | PVC 2 x 0.75 mm ² |
| | ULM-53L-__-U | PVC 3 x 0.5 mm ² |
| | ULM-53L-__-M | PVC 2 x 2 x 0.25 mm ² (twisted pair, shielded) |
| Current output load resistance (at U = 24 V DC) | | R _{max} = 270 Ω |
| Voltage output load resistance | | R > 1 kΩ |
| Delay between supply power rise time and first measurement | | Max. 5 s (by type) |
| Delay between power supply rise time and full emission output | | Max. 45 s (by type) |
| Weight (incl. 5 m length cable) | ULM-53L-02 | 0.55 kg |
| | ULM-53L-06 | 0.65 kg |
| | ULM-53L-10 | 0.95 kg |
| | ULM-53L-20 | 3.15 kg |

MOUNTING RECOMMENDATION

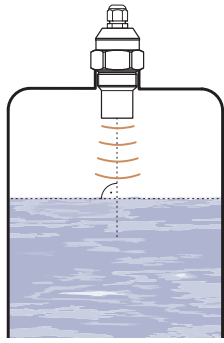

Fig. 1: Recommended installation

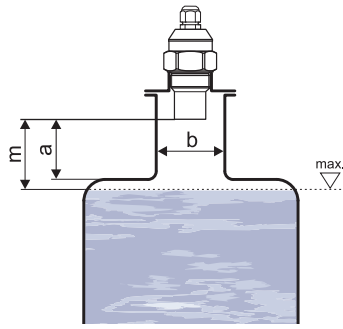
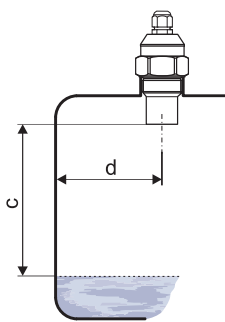

Fig. 2: Possible installation through the neck

| | |
|----------------|------------------------------------|
| ULM-53L-02; 06 | $a < 3b$ $b > 100 \text{ mm}$ |
| ULM-53L-10 | $a < 1.5b$ $b > 100 \text{ mm}$ |
| ULM-53L-20 | $a < 1.5b$ $b > 150 \text{ mm}$ |

a – Neck height
b – Neck width
m – Dead zone



c – Measuring range
d – Min. distance from tank wall

| | |
|----------------|-------------------------------|
| ULM-53L-02; 10 | $d > 1/12 c$ (min. 200 mm) |
| ULM-53L-06 | $d > 1/8 c$ (min. 200 mm) |
| ULM-53L-20 | $d > 1/10 c$ (min. 200 mm) |

Fig. 3: Installation distance from the tank wall

| | |
|-----------------|----------------------|
| ULM-53L-02; -06 | $h = 0.25 \text{ m}$ |
| ULM-53L-10; -20 | $h = 0.5 \text{ m}$ |

h – Level distance from ULM

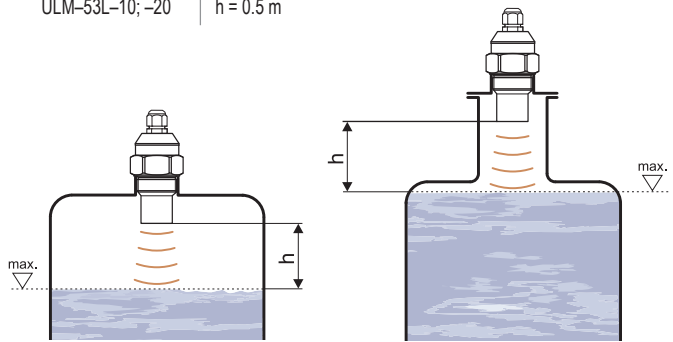

Fig. 4: Maximum level distance from ULM

ELECTRICAL CONNECTION

ULM-53L-__-I and ULM-53L-__-U

The ultrasonic level meter is designed to be connected to supply unit or to controller through two or three-wire 5 m long cable. Connection diagram as shown in Fig. 5 and 6.

Note: In case of strong electromagnetic interferences (EMI), parallel cable ducting with power lines, or when cable length exceeds 30m we recommended to use shielded cable.

ULM-53L-__-M

The connection is done by means of shielded four wires cable directly into a binary input of control system (RS-485). Connection diagram as shown in Fig. 7. Shielded cable length is 5 m.

Always disconnect the power supply before connecting the level meter electrically!

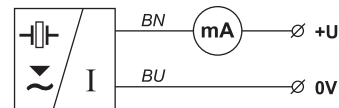

Fig. 5: Level meter connection diagram (version with current output)

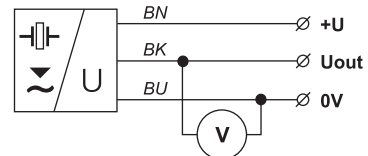

Fig. 6: Level meter connection diagram (version with voltage output)

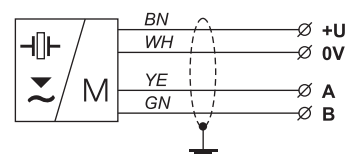

Fig. 7: Level meter connection diagram (version with RS-485 output)

Legend:

BN – Brown WH – White
BK – Black YE – Yellow
BU – Blue GN – Green

LEVEL METER SETTING

There are no setting elements on the level meters. ULM-53L-___-M type adjusting (parameterization) by RS-485 Modbus RTU protocol. For detailed information about Modbus RTU parameterization please read the instructions manual.

STATUS SIGNALIZATION

ULM-53L-___-I and ULM-53L-___-U type are produced without optical LED indication. No echo reflection or dead zone indication via current or voltage change in output. See "Technical data" table.

ULM-53L-___-M type are produced without optical LED indication. No echo reflection or dead zone indication via RS-485 Modbus RTU protocol.

ORDER CODE

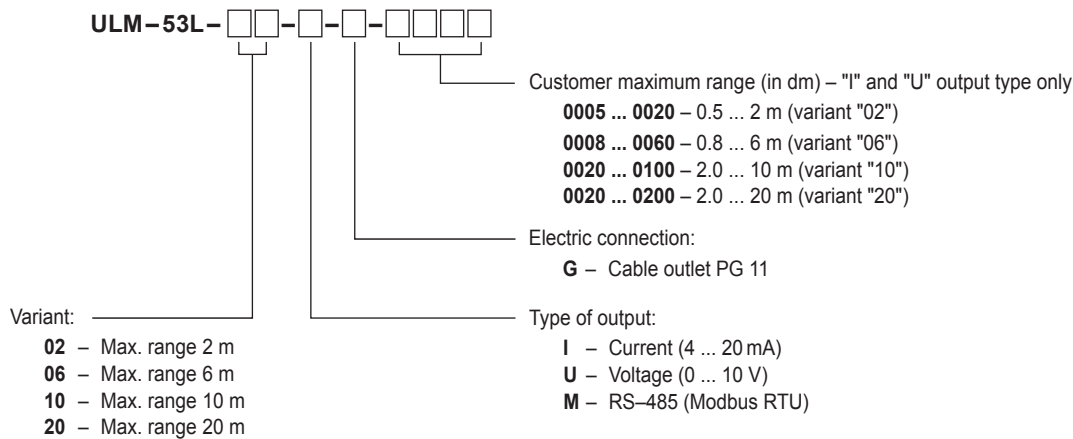

CORRECT SPECIFICATION EXAMPLES

ULM-53L-02-I-G-0015

(02) Variant 02; (I) Current output (4 ... 20 mA), (G) Electric connection by cable outlet PG 11; (0015) Customer maximum range to 1.5 m.

ULM-53L-06-M-G

(06) Variant 06; (M) RS-485 Modbus protocol output; (G) Electric connection by cable outlet PG 11.

ULM-53L-10-U-G-0090

(10) Variant 10; (U) Voltage output (0 ... 10 V); (G) Electric connection by cable outlet PG 11, Customer maximum range to 9 m.

ACCESSORIES

Standard – included in the level meter price

- 5 m of cable

Optional – for extra charge (see datasheet "Accessories")

- Fixing nut G1" (for ULM-53L-02)
- Fixing nut G1 ½" (for ULM-53L-06)

SAFETY, PROTECTIONS AND COMPATIBILITY

The level meter ULM-53L is equipped with protection against reverse polarity and output current overload.

Protection against dangerous contact is secured by low safety voltage that complies with EN 33 2000-4-41. Electromagnetic compatibility according to EN 55022/B, EN 61326/Z1 and EN 61000-4-2 to 6.